

# CWS Coil Winding Specialist

## Specification Sheet

Date: May 2004

Part No. : TS249-Y02

Rev. :

Product : TOP SWITCH TRANSFORMER

Comment :

Item	Printed Specification	Proposed Specification

Remark :

**Engineer:**

**Verified:**

**Approved by :**

# CWS Coil Winding Specialist

## Mechanical Dimension & Schematic

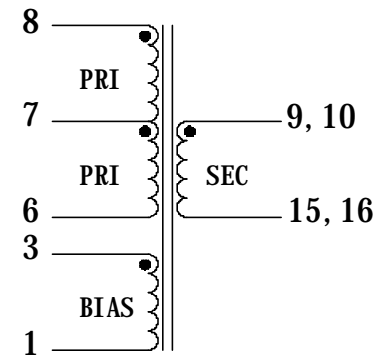
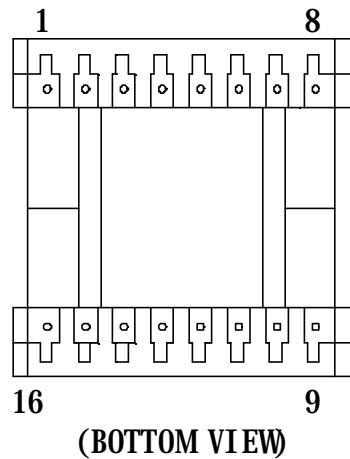
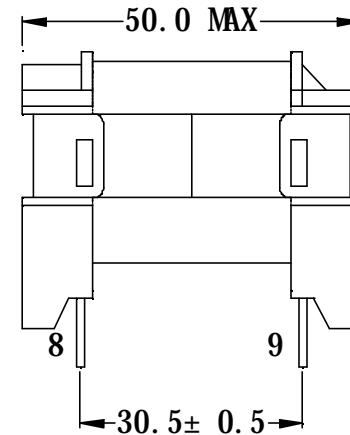
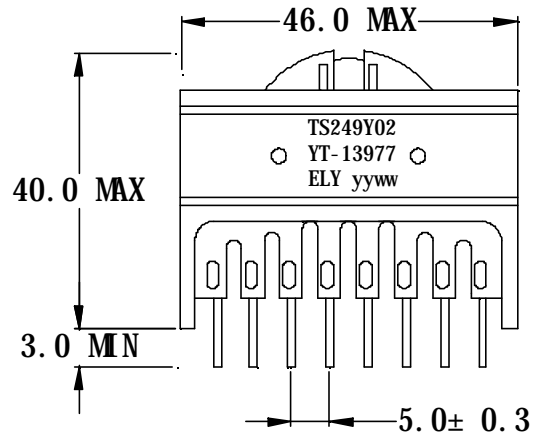

UNIT : mm

Customer :

Part No. : TS249-Y02

Rev.:

Sample No. :

# CWS Coil Winding Specialist

<b>Electrical Specification</b>												
<b>Remark :</b>												
Testing Item	Specification	Pin No.	Samples Tested Data									
			1	2	3	4	5	6	7	8	9	10
INDUCTANCE HP-4192A @100KHz,0.1V	683.0 uH ±10%	L (8-6)	694	700	699	710	683	693	691	695	700	695
LEAKAGE IND. HP-4192A @100KHz,0.1V	13.5 uH MAX PIN 9,10,15,16 SHORTED	LK (8-6)	8.1	8.5	6.5	7.2	6.7	8.4	7.4	8.8	8.3	8.0
HI-POT TEST GPT-615	3000VAC,5mA,1SEC	3,8 TO 9,10	OK	OK	OK	OK	OK	OK	OK	OK	OK	OK
<b>Customer :</b>	<b>Part No. :</b> TS249-Y02				<b>Rev.:</b>				<b>Sample No. :</b>			